

Table :01 - Door - External side

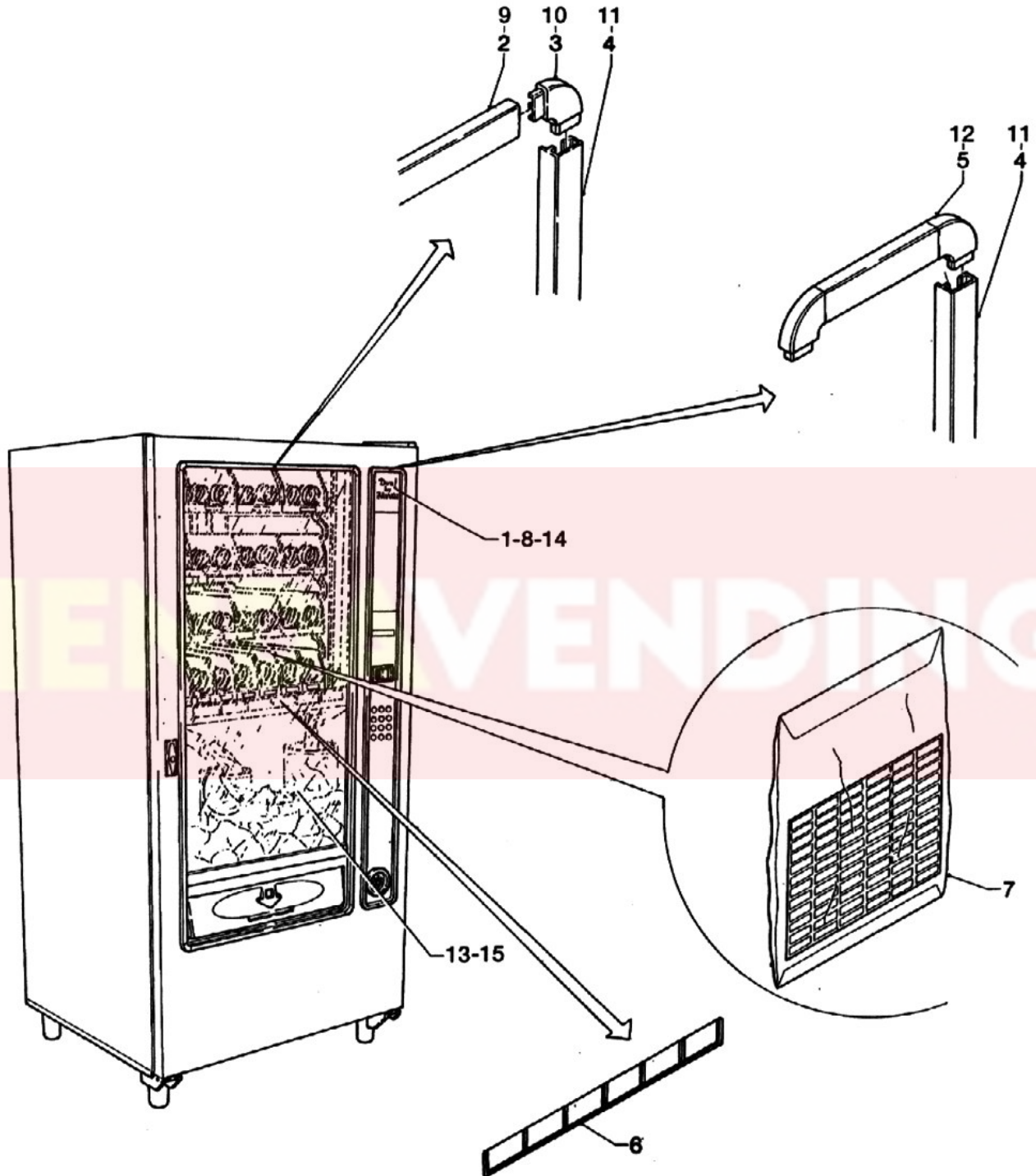

Table :01 - Door - External side

	Code	Description	Notes
1	0V0589	NECTA LOGOTYPE DUAL	
2	0V0029	HORIZONTAL PROFIL	
3	098995	PROFILES UNION	
4	098992	VERTICAL PROFILE	
5	099804	FRAME	
6	0V0584	LABEL	
7	0V0152	PRICES PLATES	
8	0V2782	LOGO PLATE (FM)	
9	0V2797	BLACK HORIZONTAL PROFILE	
10	0V0831	PROFILE JUNCTION 'BLACK'	
11	0V0823	VERTICAL PROFILE 'BLACK'	
12	0V0830	PROFILE WITH JUNCTIONS 'BLACK'	
13	0V1361	ADVERTISING PANEL	
14	0V2777	MARS ADHESIVE LABEL	
15	0V2799	ADVERTISING PANEL (CM)	

The logo for TIENDA VENDING is displayed in a large, bold, sans-serif font. The word "TIENDA" is in yellow, and "VENDING" is in white. To the right of the text is a yellow graphic element consisting of a thick, curved line that forms a partial circle, resembling a stylized 'D' or a vending machine door handle.

Table :02 - Door - Internal side

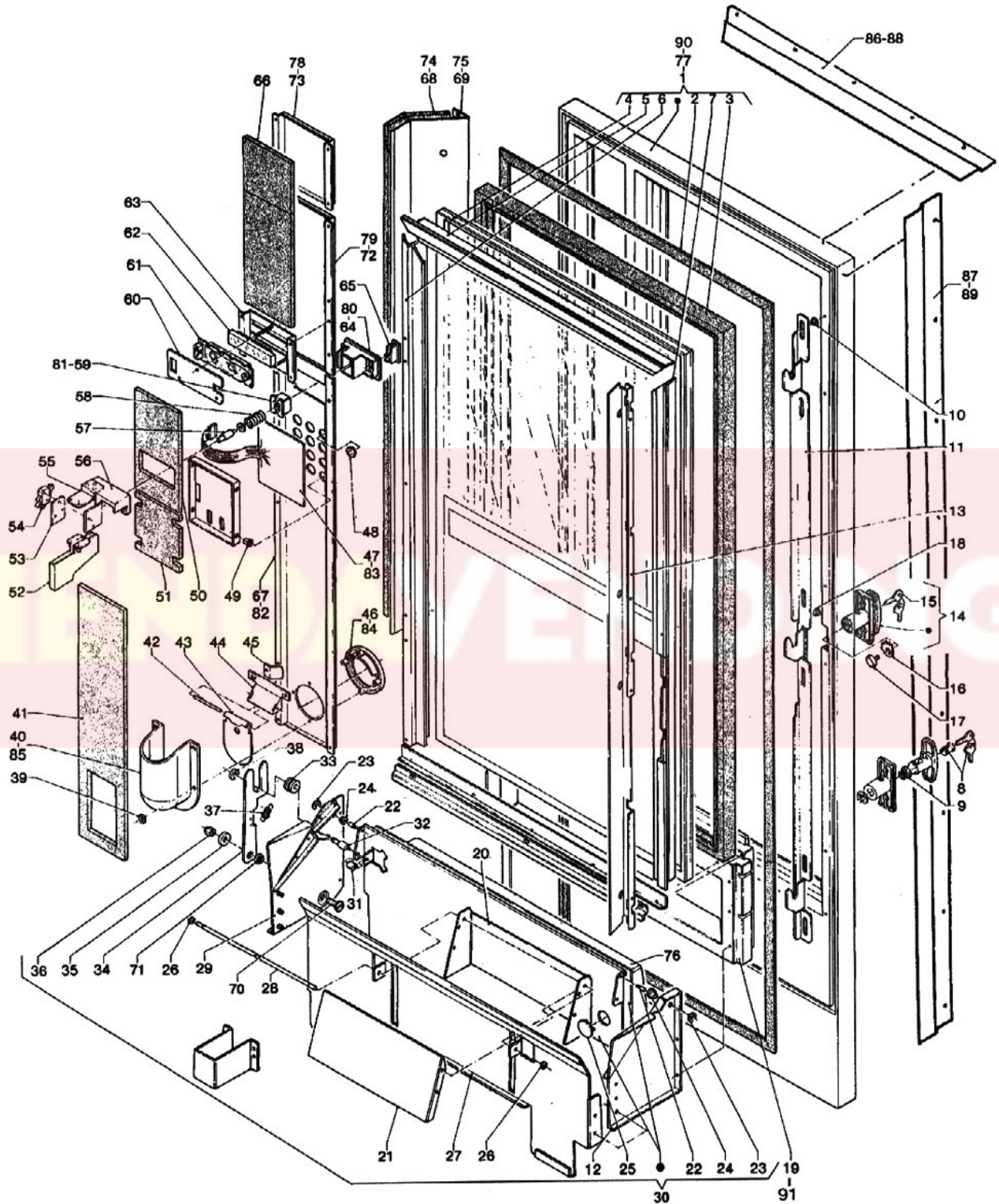

Table :02 - Door - Internal side

	Code	Description	Notes
1	0V0598	DOOR	
2	0V0203	DOOR GASKET	
3	0V0034	GLASS GASKET	
4	251571	SPRING 850 DOOR GLASS	
5	0V0036	PROFIL	
6	0V0035	PROFIL 'LEFT'	
7	0V0193	PROFIL	
8	987352	LOCK RIELDA 4000 AE045C	
9	0V1317	'T'-SHAPED LOCK HANDLE	
10	0V0040	BUSH	
11	0V0039	DOOR LOCKING	
12	0V0564	LH SLIDER PLATE	
13	0V0196	BULKHEAD	
14	985766	LOCK	
15	986200	PASS-PARTOUT M59 FOR MOD.E	
16	0V0037	PINION	
17	0V0038	SCREW	
18	0V0041	BUSH	
19	0V0032	FRAME	
20	0V0569	FRONT ANTI-THEFT	
21	0V0570	REAR ANTI-THEFT	
22	0V0058	PIN	
23	091357	OUTER BENZING COLLAR DIAM MM7	
24	0V0050	BUSH FOR PLATE	
25	094030	OUTER CAP	
26	091842	OUTER FIXING COLLAR D.2.3	
27	0V0566	SLIDER BACK PLATE	
28	0V0575	ANTI-THEFT STOP ROD	
29	0V0563	RH SLIDER PLATE	
30	0V2624	COMPLETE DOOR DUAL	
31	0V0061	SPACER FOR PIN	
32	0V0059	PIN	
33	0V0582	LEVER ROLL	
34	0V0571	SLIDER CONTROL PLATE	
35	093470	FLAT WASHER MM 6.4	
36	988234	NUT M 6	
37	0V0574	REACTION LEVER SPRING	
38	098818	STOPPING RING D.4	
39	093829	LEVER LOCK CLIP	
40	0V0071	COIN-CONVEYOR	
41	0V0201	INSULATOR	
42	093891	SHUTTER PIVOT	

Table :02 - Door - Internal side

Code	Description	Notes	
43	093890	MONEY RETURN SHUTTER	
44	097455	MONEY RETURN SHUTTER BRACKET	
45	098246	CONVEYOR FIXING BRACKET	
46	097140	MONEY RETURN FRAME (GREY)	
47	0V0070	MEMBRANE CONTROL PANEL	
48	099134	BUTTON	
49	094111	INSULATING DOLLY BLOCK	
50	0V0199	INSULATOR	
51	0V0200	INSULATOR	
52	0V0069	COIN-CHUTE	
53	090681	INSULATING DISK	
54	0V0067	MICROSWITCH	
55	0V0068	BRACKET FOR CHUTE	
56	0V0066	MICROSWITCH SUPPORT	
57	987752	RETURN BOLT	
58	987751	SPRING	
59	097395	MONEY RETURN BUTTON GREY	
60	098151	DISPLAY FIXING PLATE	
61	251690	DISPLAY 2X20BLUE	
62	0V0065	GLASS FOR DISPLAY	
63	0V0063	DISPLAY SUPPORT	
64	097394	MONEY RETURN BADGE GREY	
65	095890	LUMINOUS INDICATOR ORANGE	
66	0V0202	INSULATOR	
67	0V1942	CONTROL PANEL	
68	0V0198	INSULATOR	
69	0V0197	BULKHEAD	
70	0V0044	PIN	
71	0V0048	BUSH FOR LEVER	
72	252877	GREY DOUBLE ELEMENT	
73	253106	GREY NEUTRAL ELEMENT	
74	0V1819	LAMP INSULATION	FRENCH VERSION
75	0V1845	REFLECTING WALL	FRENCH VERSION
76	0V2794	BLACK SLIDER	
77	0V2796	WHITE DOOR (CM)	
78	0V1681	BLACK NEUTRAL ELEMENT	
79	0V0826	DOUBLE ELEMENT 'BLACK'	
80	0V0832	COIN INSERT FRAME 'BLACK'	
81	0V0835	PUSH-BUTTON 'BLACK'	
82	0V2786	CONTROL PANEL (FS)	
83	0V2793	BLACK MEMBRANE-TYPE PUSH-BUTTON PANEL	
84	0V0834	COIN RECOVERY FRAME 'BLACK'	

Table :02 - Door - Internal side

	Code	Description	Notes
85	0V2792	BLACK COIN CHUTE	
86	0V2790	WHITE DOOR UPPER ARMOR PLATING	
87	0V2788	WHITE DOOR LH ARMOR PLATING	
88	0V2772	BLACK DOOR UPPER ARMOR PLATING	
89	0V2776	BLACK DOOR LH ARMOR PLATING	
90	0V2940	BLACK DOOR (DUAL)	
91	0V2798	BLACK FRAME	

TIENDA VENDING

Table :03 - Cabinet assv

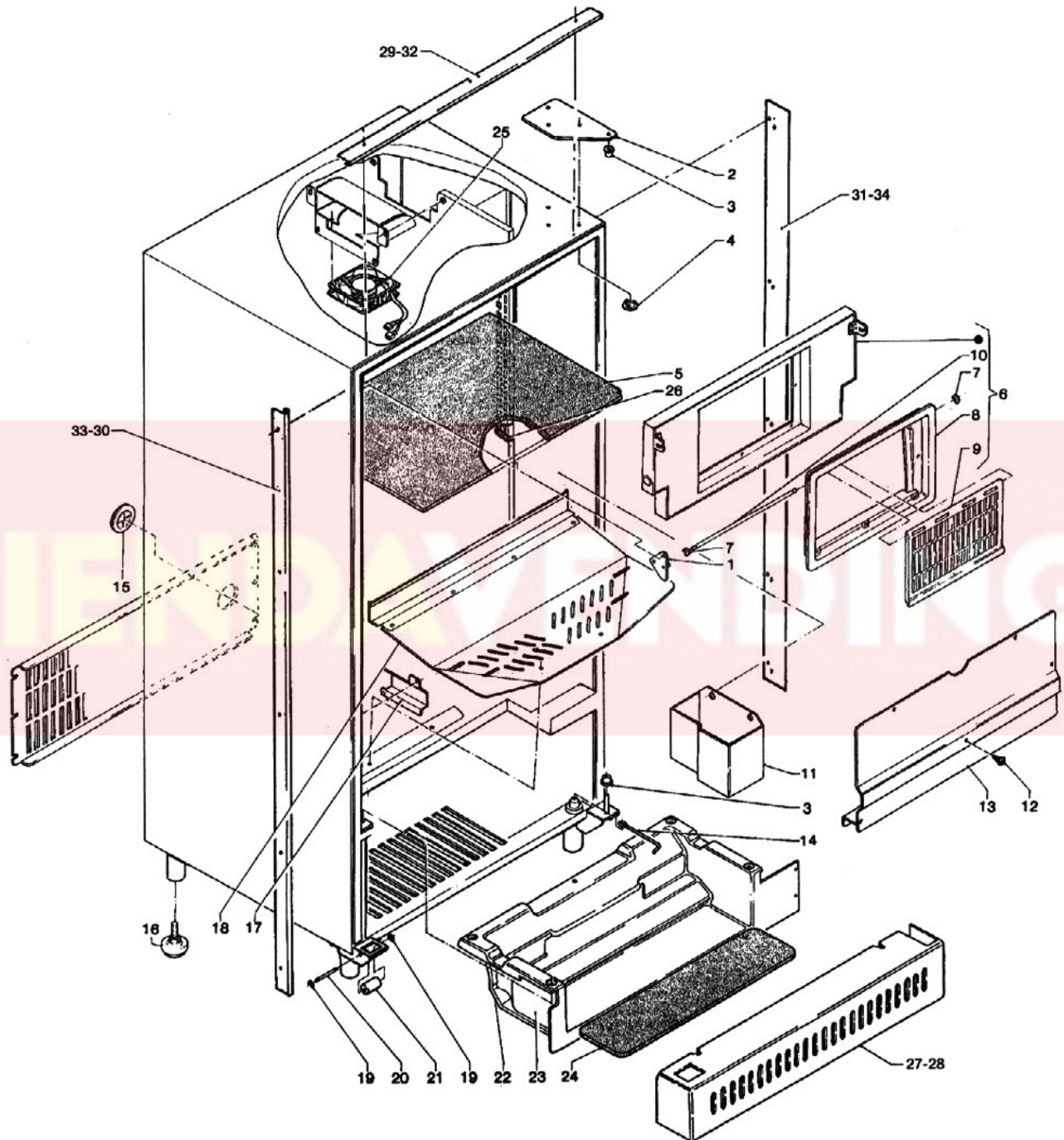

Table :03 - Cabinet assy

	Code	Description	Notes
1	0V0217	CLOSURE	
2	0V0072	UPPER HINGE	
3	0V0028	BUSH 'UPPER-LOWER'	
4	094030	OUTER CAP	
5	0V0586	SHELF INSULATION	
6	0V0599	PRODUCT OUTLET PANEL	
7	091842	OUTER FIXING COLLAR D.2.3	
8	985489	PALLET FRAME	
9	985492	BLADE	
10	985141	PIN ISOLATING DOOR BLADE	
11	0V0013	MONEY BOX	
12	092738	WEDGE BUMPER	
13	0V0565	SLIDE CASING	
14	0V0218	ROD	
15	987902	CABLE BUSHING	
16	986802	LIVELLER-FOOT	
17	0V0568	DEVIATOR	
18	0V0577	CHUTE	
19	091959	BENZING COLLAR DIAM MM4	
20	0V0000	PIN	
21	0V0001	ROLLER	
22	0V0585	COMPARTMENT INSULATION	
23	0V0576	PRODUCT COMPARTMENT	
24	0V0212	PANEL	
25	987640	FAN	
26	0V0587	LH-RH SIDE INSULATION	
27	0V0150	FRONT PEDESTAL SCREEN	
28	0V0847	FEET COVER -BLACK-	
29	0V2791	WHITE CABINET UPPER ARMOR PLATING	
30	0V2789	WHITE CABINET LH ARMOR PLATING	
31	0V2787	WHITE CABINET RH ARMOR PLATING	
32	0V2773	BLACK CABINET UPPER ARMOR PLATING	
33	0V2775	BLACK CABINET LH ARMOR PLATING	
34	0V2774	BLACK CABINET RH ARMOR PLATING	

Table :04 - Electric panel

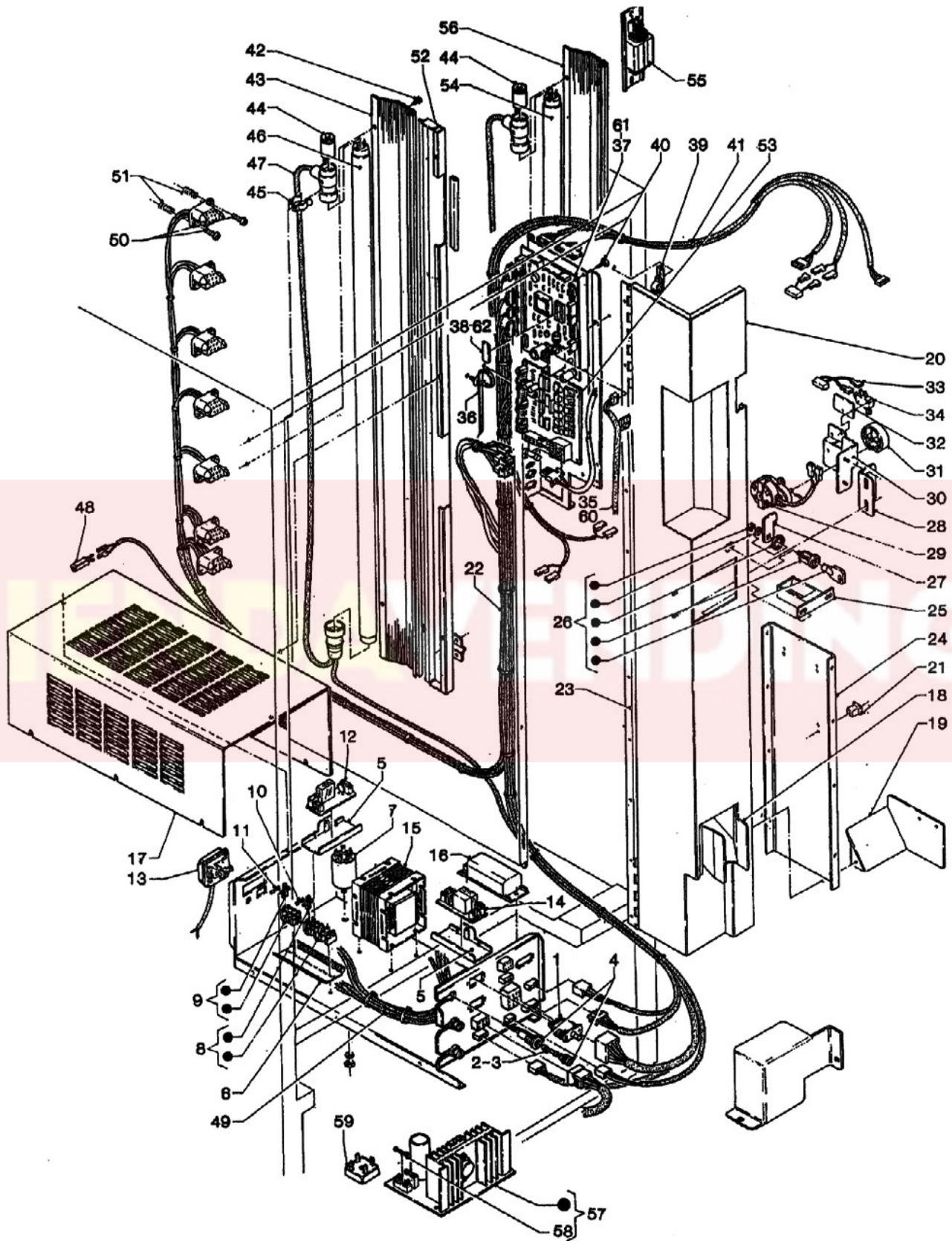

Table :04 - Electric panel

	Code	Description	Notes
1	986058	DOOR-MICRO WITH RESETTING	
2	098779	FUSE 6.3X32 1 AMP	
3	097489	FUSE 250V-10A DELAYED ACTION	
4	0V3201	FUSE HOLDER	
5	094849	COVERING-HOLDER	
6	097242	SUB-TERMINAL BOARD	
7	0V3512	ELECTRICAL NET FILTER	
8	098793	5P TERMINAL BOARD WITH FUSE-HOLDER	
9	097241	3-POLE TERMINAL BOARD W/CARRIER	
10	097259	FUSE 5X20 4A DELAYED ACTION	
11	097368	FUSE 5X20 630 MA DELAYED ACTION	
12	0V0016	OUTR-VARISTOR CARD	
13	098796	TERMINAL BOARD	
14	0V0015	OUTR CARD	
15	987219	TRANSFORMER	
16	091803	REACTOR TYPE 58443 HQ/3 220V	
17	0V0017	COVERING	
18	0V0009	CHUTE FOR CHANGE	
19	0V0010	COINS CONVEYOR	
20	0V1624	COVER	
21	094111	INSULATING DOLLY BLOCK	
22	0V0590	MAIN WIRING	
23	0V0055	HINGE	
24	0V0008	COIN MECHANISM SUPPORT	
25	0V0007	COINS INTRODUCTION CHUTE	
26	0V0359	LOCK 'MERONI'	
27	098756	DOOR BOLT	
28	0V0219	BRACKET	
29	099754	MOTOREDCER	
30	0V0005	BRACKET	
31	0V0006	CAM	
32	090681	INSULATING DISK	
33	096845	FILTER RC 1000HM 0.1MF	
34	0V1927	MICROSWITCH 'UL'	
35	0V1759	EXECUTIVE-MDB WIRING	
36	090148	CLIP	
37	0V0862	CPU/CONTROL BOARD 'PLUS'	
38	095004	EPROM 512K(TO BE PROGRAMMED)	
39	091420	ADJUSTABLE COLLAR	
40	097175	CARD SPACER	
41	0V0062	WIRING DOOR 'SPRING/DUAL'	
42	0V0003	CLIPS	

Table :04 - Electric panel

Code	Description	Notes	
43	0V0583	LAMP PANEL	
44	091802	STARTER TYPE S10	
45	098337	LAMP-HOLDER HOOKS	
46	0V0594	NEON	
47	0V0593	LAMP WIRING	
48	986060	ELECTRONIC SENSOR K277	
49	0V0591	ELECTRICAL PANEL WIRING	
50	0V1285	SCREW	
51	987751	SPRING	
52	0V0562	REFLECTING PANEL	
53	0V0888	OPERATING BOARD	
54	986531	NEON LIGHT 38 WATT	2ND LAMP KIT
55	987367	36-40WATT BALLAST	2ND LAMP KIT
56	0V0002	PANEL	2ND LAMP KIT
57	097808	FEEDING BOARD	BDV VERSION
58	097097	FUSE 2 AMP.5X20 DELAYED ACT	BDV VERSION
59	094900	DIODE BRIDGE	BDV VERSION
60	0V0842	BDV SPIRAL WIRING	BDV VERSION
61	0V0862	CPU/CONTROL BOARD 'PLUS'	
62	099982	1024K-EPROM (TO BE PROGRAMMED	

Table :05 - Tray and drawers

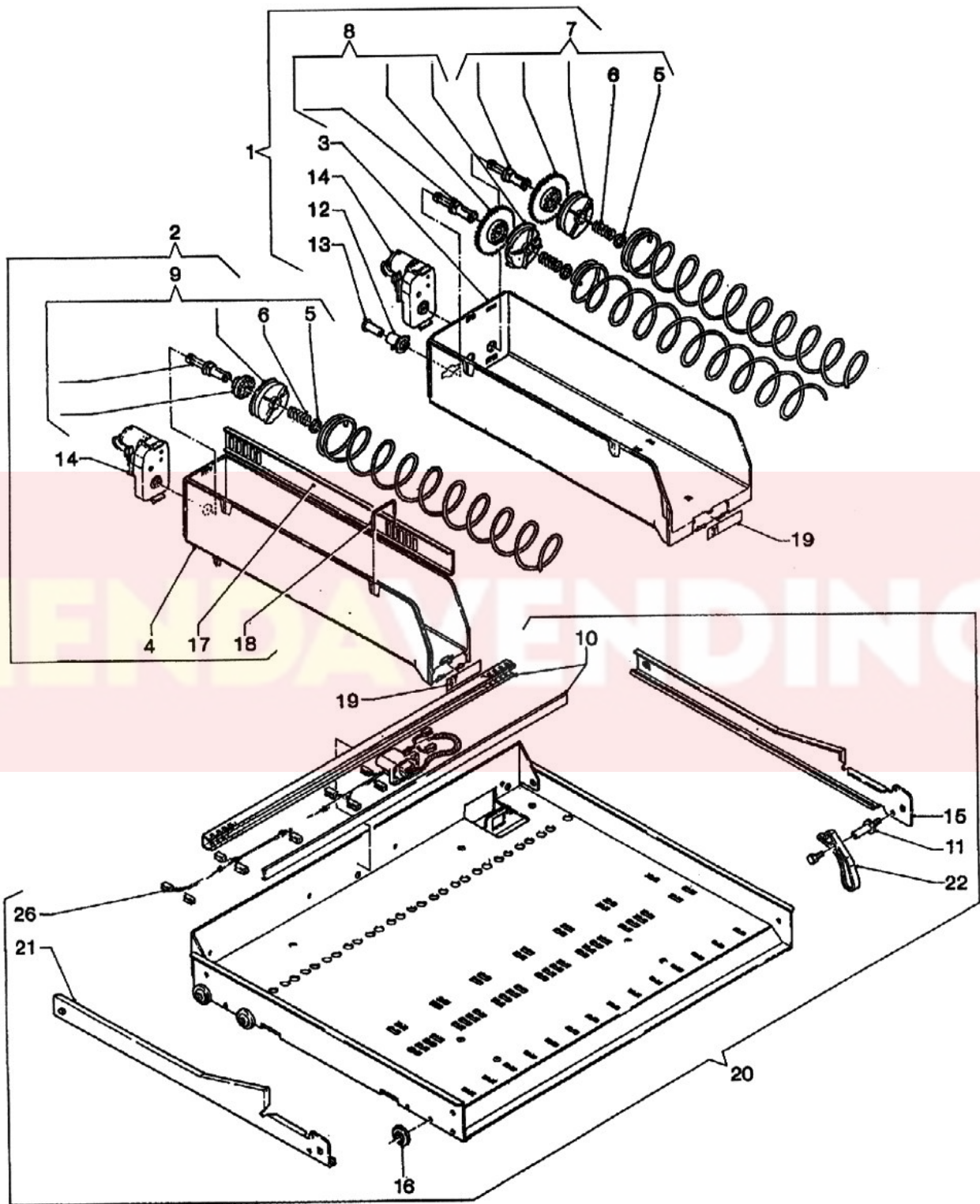

Table :05 - Tray and drawers

	Code	Description	Notes
1	0V0073	DRAWER 'LARGE' COMPLET	
2	0V0085	DRAWER 'SMALL' COMPLET	
3	0V0074	DRAWER 'LARGE'	
4	0V0086	DRAWER 'SMALL'	
5	0V0084	WASHER	
6	0V0083	SPRING	
7	0V1354	RIGHT FLANGE ASSY.	
8	0V1355	LEFT FLANGE ASSY.	
9	0V1353	FLANGE ASSY.	
10	0V0107	CANAL	
11	0V0105	PIN FOR LEVER	
12	0V0080	BUSH FOR PIN	
13	0V0079	BUSH	
14	0V0075	MOTOREDUCER	
15	0V0103	RIGHT RUNNER	
16	0V0102	ROLLER	
17	0V0089	PRODUCT RUNNER	
18	0V0088	PIN	
19	0V0111	DRAWER PLATE	
20	0V0100	MIDDLE-SIZE TRAY	
21	0V0104	LEFT RUNNER	
22	0V0106	LEVER FOR TRAY	
26	0V0108	WIRING DRAWER	

Table :06 - Coils

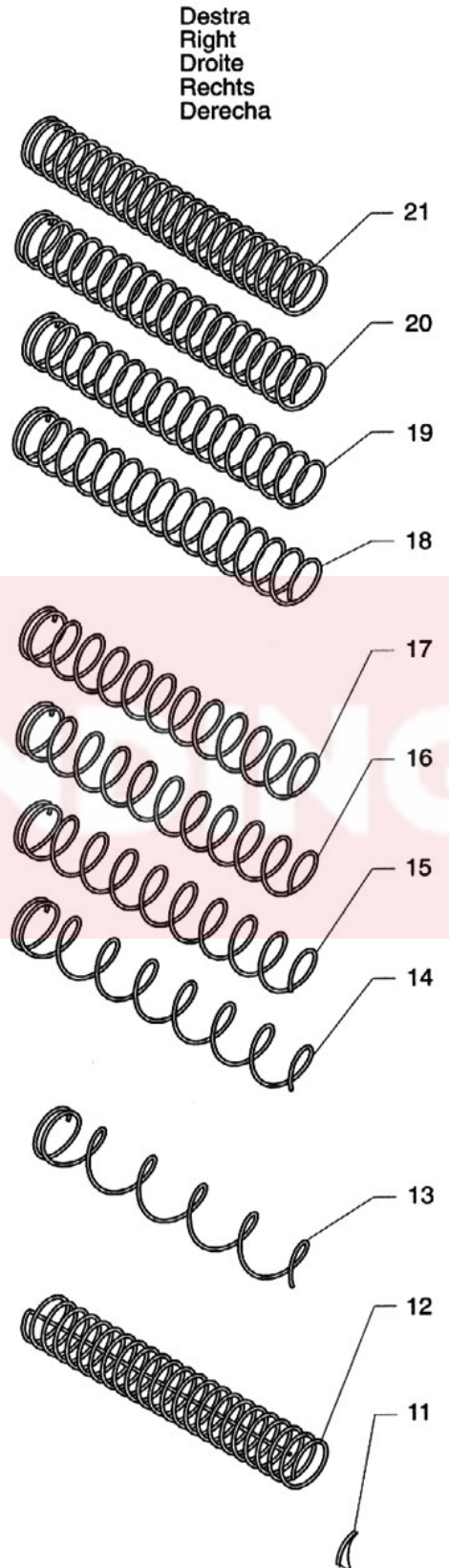
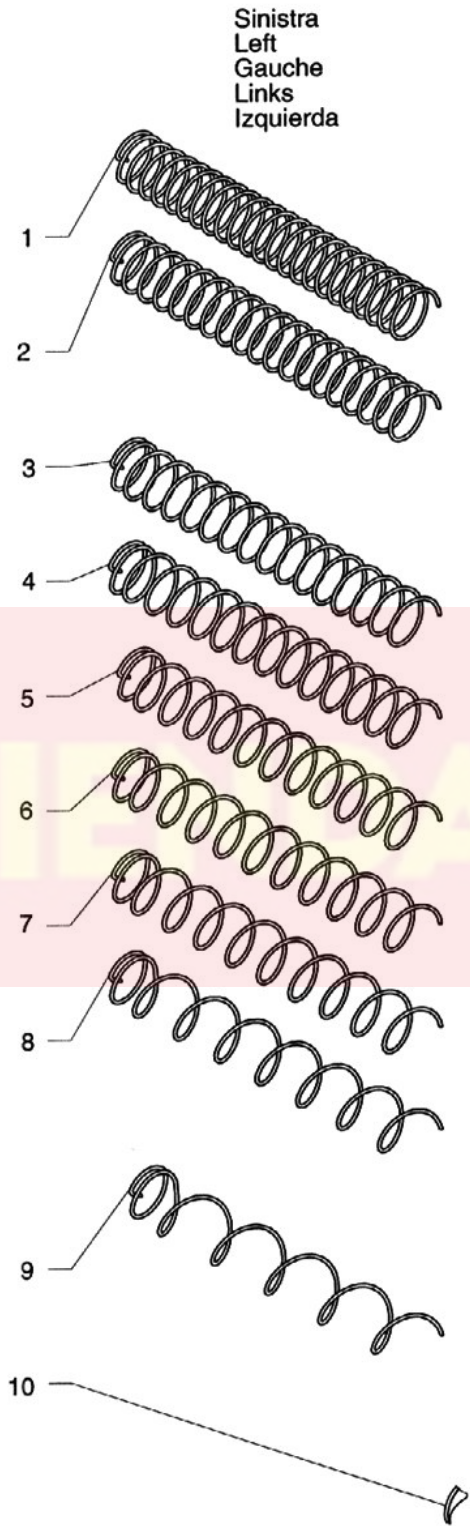

Table :06 - Coils

	Code	Description	Notes
1	0V0147	LEFT COIL D.65/P.21	
2	0V0146	LEFT COIL D.65/P.24	
3	0V0145	LEFT COIL D.65/P.30	
4	0V0144	LEFT COIL D.65/P.34	
5	0V0090	LEFT COIL D.65/P.40	
6	0V0091	LEFT COIL D.65/P.46	
7	0V0096	LEFT COIL D.65/P.54	
8	0V0143	LEFT COIL D.65/P.64	
9	0V0113	LEFT COIL D.65/P.84	
10	0V0099	LEFT EJECTOR	
11	0V0098	RIGHT EJECTOR	
12	0V0115	COIL D.65/P.24-1/2 TURN	
13	0V0112	RIGHT COIL D.65/P.84	
14	0V0141	RIGHT COIL D.65/P.64	
15	0V0097	RIGHT COIL D.65/P.54	
16	0V0092	RIGHT COIL D.65/P.46	
17	0V0093	RIGHT COIL D.65/P.40	
18	0V0094	RIGHT COIL D.65/P.34	
19	0V0095	RIGHT COIL D.65/P.30	
20	0V0142	RIGHT COIL D.65/P.24	
21	0V0148	RIGHT COIL D.65/P.21	

Table :07 - Trollev

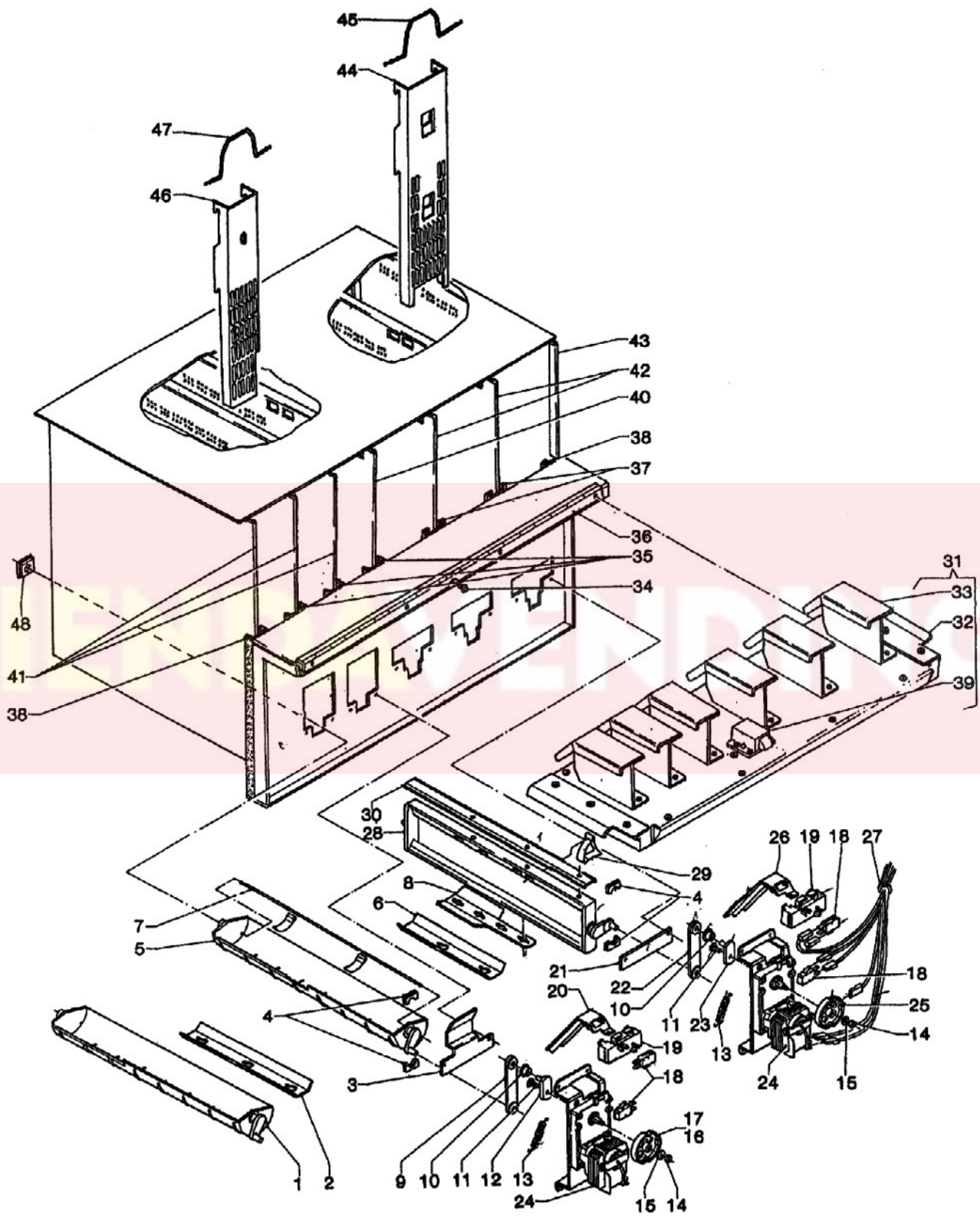

Table :07 - Trolley

Code	Description	Notes
1	987310	OSCILLATING ROTOR
2	0V0573	SALES PLATE 3X0.33
3	986710	PLATE
4	985455	FRONT HALF-BUSH
5	0V0921	0.25 CAN ROTOR
6	0V0920	0.25 CAN PLATE
7	987006	ANTITHEFT-DEVICE OF SINGLE ROTOR ASS.
8	0V0572	DOUBLE COLUMN PLATE
9	985462	ROTOR TRACE
10	985826	CONNECTING ROD BUSH
11	985970	SCREW FOR MOTOR-FLANGE
12	986240	TRACE FOR MOTOREDUCER
13	985411	SPRING
14	985318	NUT
15	093470	FLAT WASHER MM 6.4
16	985835	CAM (PET 0.5 CANS 2X0.25-2X0.33)
17	985464	CAMS (CANS 3X0.33)
18	985834	MICROSWITCH
19	985460	BLADE-SUPPORT
20	987034	FULL/EMPTY SQUARE PIECE
21	985824	DISC FOR HALF-BUSH
22	985055	TRACE MM81 ROTOR OSCILL
23	986072	MOTOREDUCER TRACE
24	986069	MOTOREDUCER
25	986487	MICROSWITCH COMMAND CAM
26	985110	BLADE EMPTY FULL
27	0V0592	SLIDE WIRING
28	986649	OSCILLATING ROTOR
29	986392	ANTITHEFT-SPRING
30	0V0919	UPPER PLATE
31	0V0597	SLIDER
32	0V1321	LOCKING PROFILE
33	0V0567	PLATE
34	093823	NOZZLE FASTENER DOLLY BLOCK
35	0V0580	SINGLE COLUMN PROFILE
36	0V0754	SLIDER HINGE
37	0V0579	FRONT PROFILE
38	0V0581	DOUBLE COLUMN PROFILE
39	0V1332	LOCKING DEVICE
40	0V0558	INTERMEDIATE COLUMN
41	0V0557	SINGLE COLUMN
42	0V0925	DOUBLE COLUMN

Table :07 - Trolley

Code	Description	Notes
43	0V0924	SIDE COLUMN
44	0V0559	COLUMN BACK SIDE
45	986790	PILLAR-REAR SPRING
46	0V0560	COLUMN BACK SIDE
47	0V1310	BACKCOLUMN SPRING
48	985822	POST. BUSH CARRIAGE ROTOR



Table :08 - Cooling unit

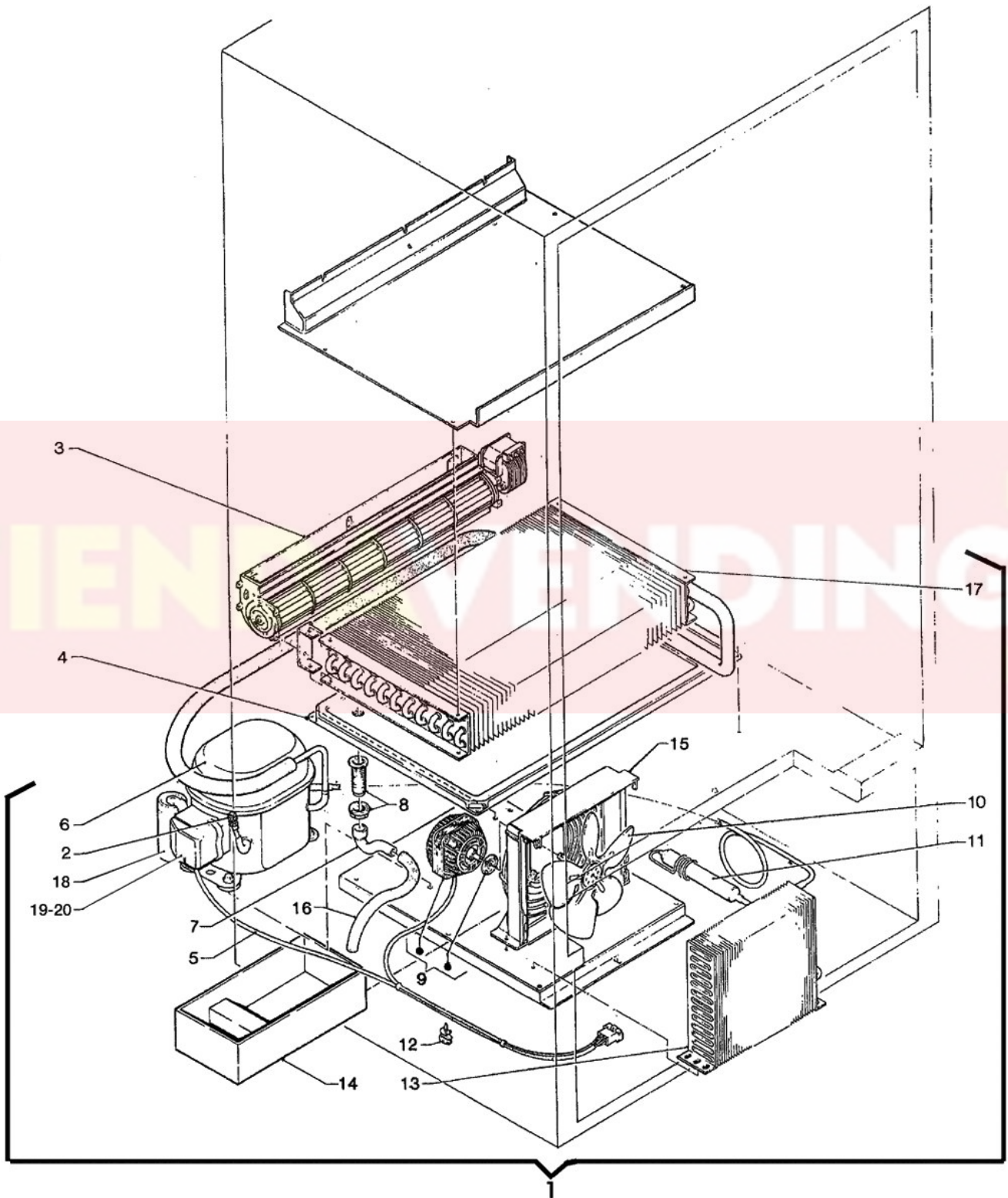

Table :08 - Cooling unit

	Code	Description	Notes
1	0V0600	REFRIGERATING UNIT	
2	985603	RECHARGE VALVE	
3	0V0595	ELECTRICAL FAN	
4	0V0578	CONDENSATE COLLECTION TRAY	
5	0V0732	COOLING UNIT WIRING	
6	0V0734	T6213Z COMPRESSOR	
7	987853	SIPHON	
8	987982	TUBE	
9	0V0733	FAN MOTOR	
10	985049	IMPELLER	
11	987293	FILTER 40 GR.	
12	098166	WIRE-FIXING	
13	0V0735	16T CAPACITOR	
14	0V0731	EVAPORATOR TRAY	
15	0V0730	FAN PROTECTION	
16	098719	PVC PIPE 14X19(A METER)	
17	0V0736	EVAPORATOR	
18	0V2662	CAPACITOR 88-108 Uf	
19	0V2660	COMPRESSOR PROTECTION AND RELAY	
20	0V2660	COMPRESSOR PROTECTION AND RELAY	